

Module 1

Electronic Circuits

Power Supplies: Block diagram, Rectifiers, Reservoir and smoothing circuits, Full-wave rectifiers, Bi-phase rectifier circuits, Bridge rectifier circuits, Voltage regulators, Output resistance and voltage regulation, Voltage multipliers.

Amplifiers: Types of amplifiers, Gain, Input and output resistance, Frequency response, Bandwidth, Phase shift, Negative feedback, Multi-stage amplifiers.

Operational amplifiers: Operational amplifier parameters, Operational amplifier characteristics, Operational amplifier configurations, Operational amplifier circuits.

Oscillators: Positive feedback, Conditions for oscillation, Ladder network oscillator, Wein bridge oscillator, Multivibrators, Single-stage astable oscillator, Crystal controlled oscillators.

1.1 POWER SUPPLIES

1.1.1 Block Diagram

- Power supply is a device that supplies electric power to a load.
- The block diagram of a d.c. power supply is shown in Fig. 1.1.
- **Step-down transformer:** The high voltage a.c. input (220-240V) is converted to a low voltage (5V, 9V, 12V etc.) using a step-down transformer of appropriate turns ratio.
- **Rectifier:** The a.c. output from the transformer secondary is then rectified using conventional silicon rectifier diodes to produce an unsmoothed (pulsating d.c.) output.
- **Reservoir/Filtering Circuit:** The unsmoothed output from rectifier is smoothed by reservoir/filtering circuit (a high value capacitor). The capacitor helps to smooth out the voltage pulses produced by the rectifier.
- **Voltage Regulator:** The stabilizing circuit (a series transistor regulator and a Zener diode voltage reference) stabilizes and produces a constant voltage.

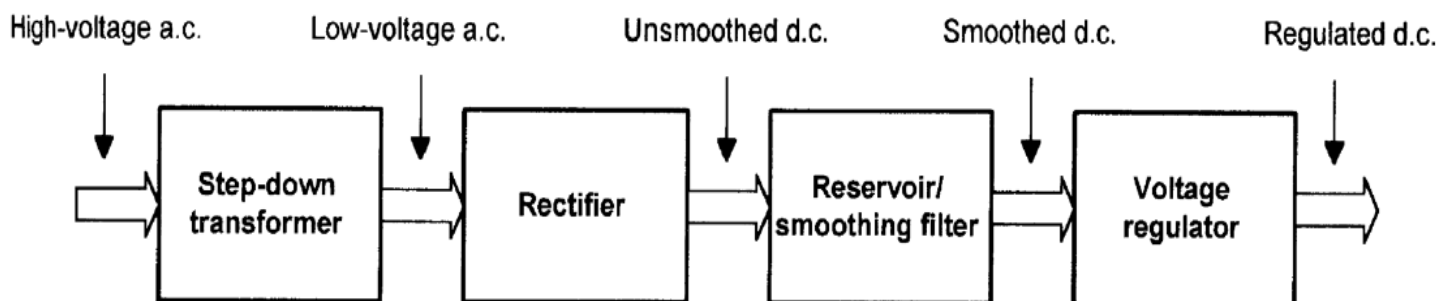

Fig. 1.1: Block diagram of d.c. power supply

1.1.2 Rectifiers

- A rectifier is a device that converts alternating current (ac) to direct current (dc).
- Semiconductor diodes are commonly used for converting ac to dc.
- Rectifiers can be classified as:
 1. Half wave rectifier.
 2. Full wave rectifier.
 - Bi-phase rectifier.
 - Bridge rectifier.

1.1.3 Half wave rectifiers

- The simplest form of rectifier circuit uses a single diode and operates only in positive or negative half cycles of the supply, known as half-wave rectifier.
- Figure 1.2 shows a simple half wave rectifier circuit.

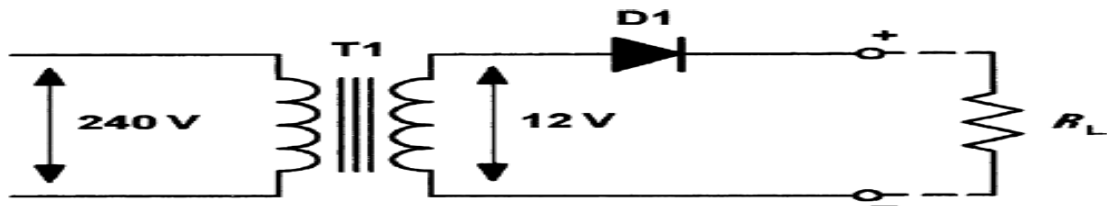

Fig. 1.2: A simple half-wave rectifier circuit

- The mains voltage (220 to 240V) applied to primary of step-down transformer.
- Secondary of transformer steps down the 240V rms to 12V rms (turns ratio 20:1).
- **Operation:** Diode D1 will allow the current to flow in the direction is shown in fig. 1.3.
- D1 will be forward biased during each positive half-cycle & behaves as a closed switch.
- When the circuit current flows in opposite direction, the voltage bias across the diode will be reversed, causing the diode to be reverse biased and act like an open switch.

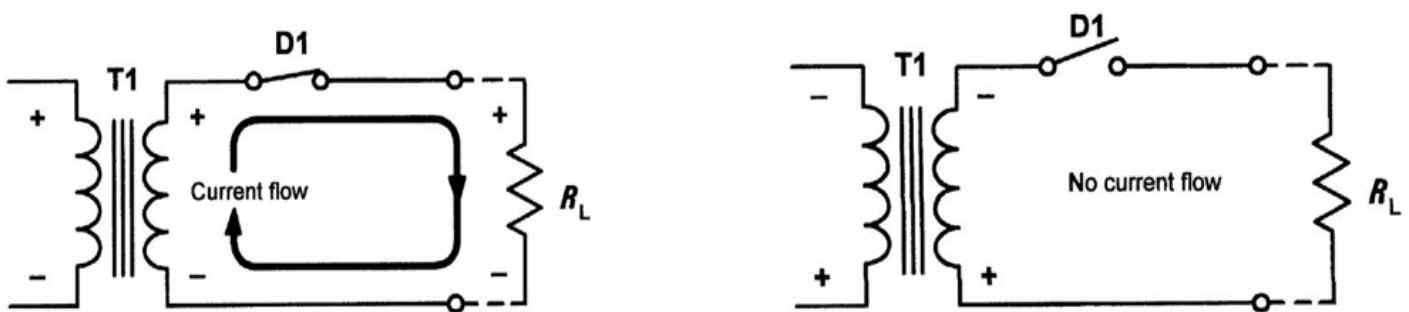

Fig. 1.3: (a) D1 conducting (positive half cycle)

(b) D1 not conducting (negative half cycle)

- Switching action of D1 results in a **pulsating output voltage** across the load R_L .

- During the positive half-cycle, the diode will drop 0.6V to 0.7V forward threshold voltage normally associated with silicon diodes.
- However, during the negative half-cycle the peak ac voltage will be dropped across D1 when it is reverse biased.

Problem 1.1: A mains transformer having a turns ratio of 44:1 is connected to a 220 V rms. mains supply. If the secondary output is applied to a half-wave rectifier, determine the peak voltage that will appear across a load.

Solution: The rms secondary voltage is be given by:

$$V_s = V_p / 44 = 240 / 44 = 5V$$

The peak voltage developed after rectification will be

$$V_{pk} = 1.414 \times 5 = 7.07V$$

The actual peak voltage dropped across the load will be (Assuming Silicon diode):

$$V_L = 7.07 - 0.6 = 6.47V$$

Half Wave Rectifier with a Reservoir Capacitor

- Figure 1.4 (a) shows a Half Wave Rectifier with a Reservoir Capacitor.
- During the first positive half-cycle, output from secondary will charge C1 to peak value seen across R_L . Hence C1 charges to maximum at the peak of positive half-cycle (16.3V).
- The time required for C1 to discharge is very much greater and is determined by the capacitance value and the load resistance, R_L .
- During this time, D1 will be reverse biased & will be held in its non-conducting state.
- As a consequence, the only discharge path for C1 is through R_L .

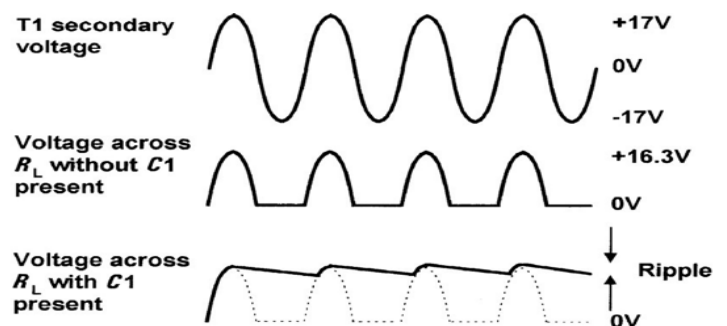
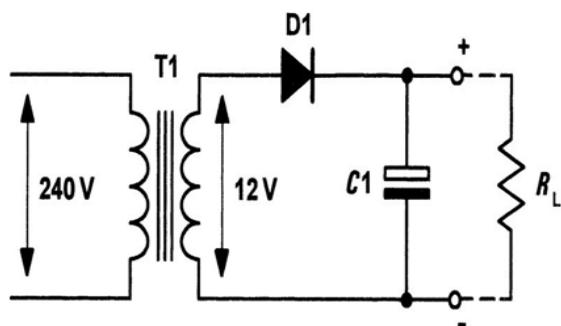

Fig. 1.4: (a) Half wave rectifier with Reservoir Capacitor

(b) Voltage Waveforms

- C1 is referred to as a **reservoir** capacitor. It stores charge during the positive half cycles of secondary voltage and releases it during the negative half-cycles.
- The circuit of Fig. 1.4(a) is thus able to maintain a constant output voltage across R_L .
- Fig. 1.4(b) shows the secondary voltage waveform together with the voltage developed across R_L with and without C1 present.

Half wave Rectifier with Smoothing Circuit

- Output of reservoir circuit consists of ripple which is undesirable & shall be removed.
- Figure 1.5 shows half wave rectifier's circuit with smoothing filters.
- Two components R & C or L & C acts as a filter to remove ripple.
- The amount of ripple is reduced by an approximate factor equal to:

$$\frac{X_C}{\sqrt{R^2 + X_C^2}}$$

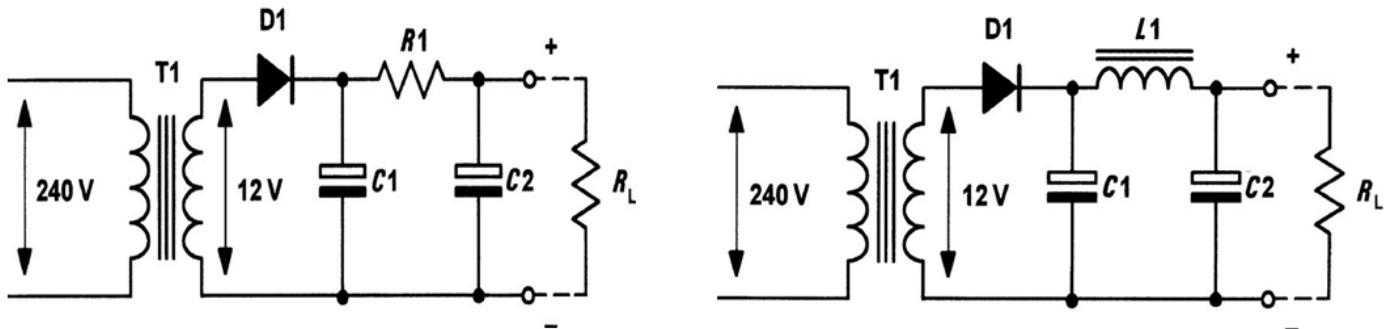

Fig 1.5: (a) Half wave rectifier with R-C smoothing filter (b) Half wave rectifier with L-C smoothing filter

Problem 1.2: The R-C smoothing filter in a 50 Hz mains operated half-wave rectifier circuit consists of $R_1 = 100\Omega$ and $C_2 = 1,000\mu\text{F}$. If 1 V of ripple appears at the input of the circuit, determine the amount of ripple appearing at the output.

Solution: The reactance of the capacitor, C_2 , at the ripple frequency (50 Hz):

$$X_C = \frac{1}{2\pi fC} = \frac{1}{6.28 \times 50 \times 1,000 \times 10^{-6}} = 1000/314 = 3.18 \text{ ohm}$$

The amount of ripple at the output of the circuit is given by:

$$V_{\text{ripple}} = 1 \times \frac{X_C}{\sqrt{R^2 + X_C^2}} = 1 \times \frac{3.18}{\sqrt{100^2 + 3.18^2}} = 0.032\text{V} = 32 \text{ mV}$$

1.1.4 Full Wave Rectifiers

- The rectifier circuit that can convert both positive and negative half cycles of ac signal into dc signal are called full wave rectifier circuits.
- The two basic forms of full wave rectifier are: Bi-phase type and Bridge rectifier type.

1.1.5 Bi-Phase Full Wave Rectifiers

- Fig. 1.6 shows a simple bi-phase rectifier circuit.
- Mains voltage (240 V) is applied to the primary of the step-down transformer (T1) which has two identical secondary windings, each providing 12 V rms.
- On positive half-cycles, point A will be positive with respect to point B and point B will be positive with respect to point C. In this condition D1 will allow conduction while D2 will not allow conduction. Thus D1 alone conducts on positive half-cycles.

- On negative half-cycles, point C will be positive with respect to point B and point B will be positive with respect to point A. In this condition D2 will allow conduction while D1 will not allow conduction. Thus D2 alone conducts on negative half-cycles.
- The operation of the bi-phase rectifier circuit with the diodes replaced by switches is shown in Fig. 1.7. In fig. 1.7 (a) D1 is shown conducting on a positive half-cycle while in Fig. 1.7 (b) D2 is shown conducting.

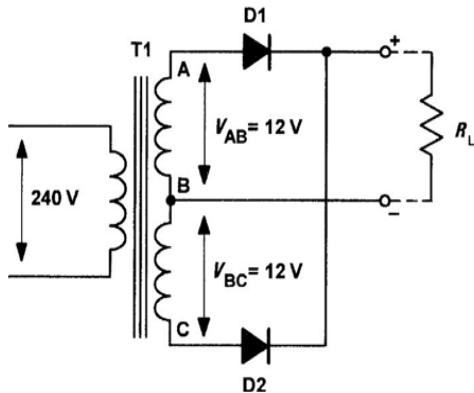

Fig. 1.6: Bi-Phase Rectifier Circuit

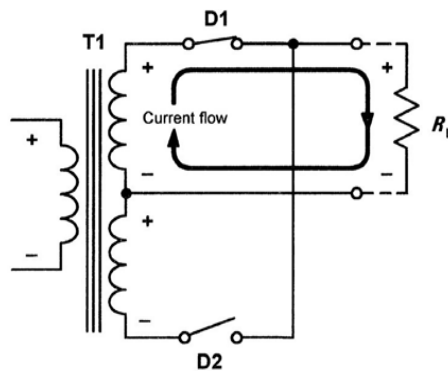
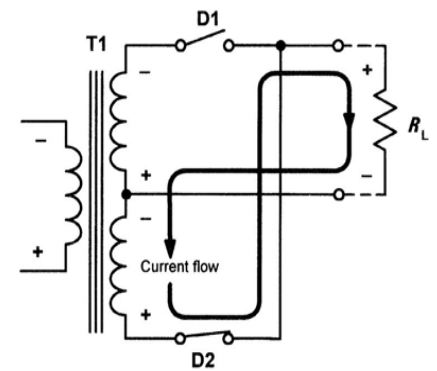

Fig. 1.7: (a) Bi-phase rectifier with D1 conducting & D2 not conducting



(b) Bi-phase rectifier with D2 conducting & D1 not conducting

Bi-Phase Rectifier with Reservoir Circuit

- Fig. 1.8(a) shows a reservoir capacitor C1 connected to ensure that the output voltage remains at, or near, the peak voltage even when the diodes are not conducting.
- The C1 charges to maximum (16.3V) at the peak of the positive half-cycle and holds the voltage at this level when the diodes are in their non-conducting states.
- The time required for C1 to discharge is very much greater and is determined by the capacitance value and the load resistance RL.
- During this time, D1 and D2 will be reverse biased and held in a non-conducting state. As a consequence, the only discharge path for C1 is through RL.
- Fig. 1.8(b) shows voltage waveforms with and without C1 present.

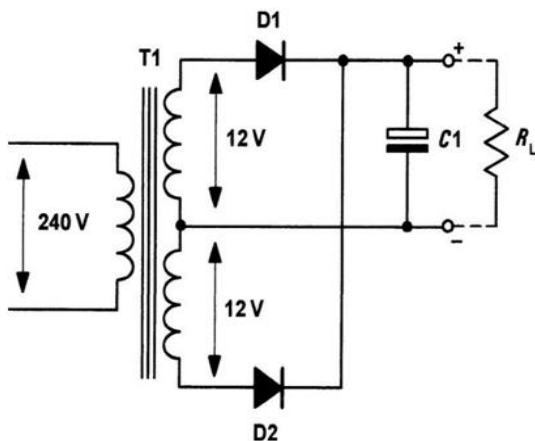
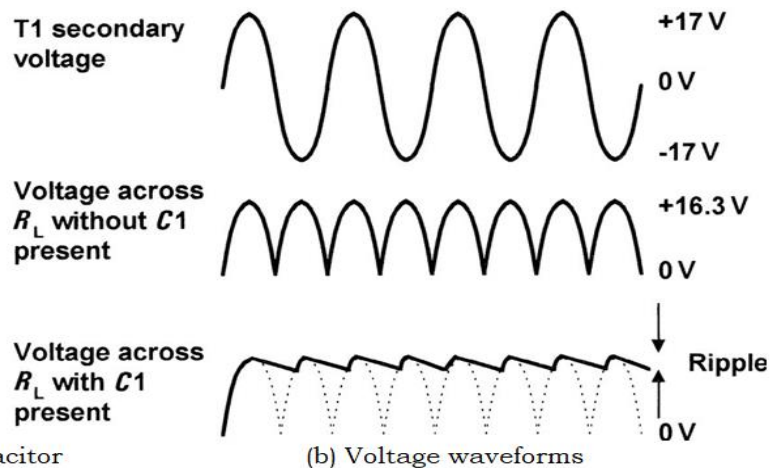

Fig. 1.8: (a) Bi-phase rectifier with reservoir capacitor



1.1.6 Bridge Rectifier

- An alternative to the use of the bi-phase circuit is that of using a four-diode bridge rectifier in which opposite pairs of diode conduct on alternate half-cycles.
- This arrangement avoids the need to have two separate secondary windings.
- A full-wave bridge rectifier arrangement is shown in Fig. 1.9.
- Mains voltage (240V) is applied to the primary of a step-down transformer (T1).
- The secondary winding provides 12V rms and has a turns ratio of 20:1.
- On positive half-cycles, point A will be positive with respect to point B. In this condition D1 and D2 will allow conduction while D3 and D4 will not allow conduction.
- On negative half-cycles, point B will be positive with respect to point A. In this condition D3 and D4 will allow conduction while D1 and D2 will not allow conduction.

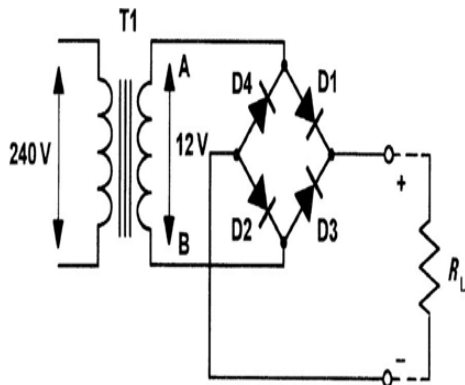

Fig. 1.9: Full wave Bridge Rectifier Circuit

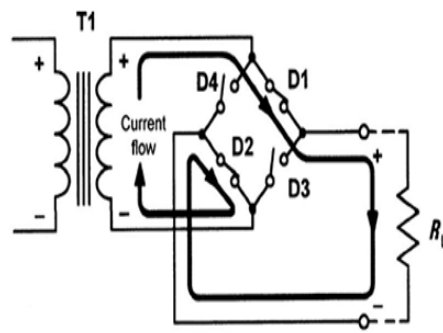
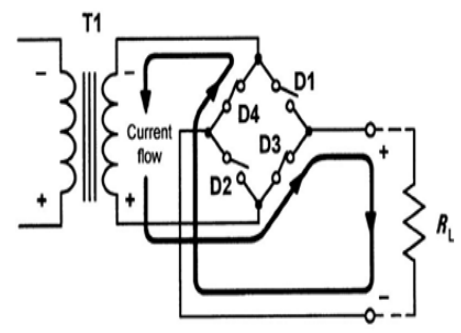

Fig. 1.10: (a) Bridge Rectifier with D1 & D2 conducting and D3 & D4 not conducting



(b) Bridge Rectifier with D1 & D2 not conducting and D3 & D4 conducting

- Fig. 1.10 shows the bridge rectifier circuit with the diodes replaced by four switches. D1 & D2 are conducting on positive half-cycle (fig. a) while D3 & D4 are conducting on negative half cycle (fig. b).

Bridge Rectifier with Reservoir Capacitor

- Fig. 1.11(a) shows a reservoir capacitor C1 connected to ensure that the output voltage remains at, or near, the peak voltage even when the diodes are not conducting.

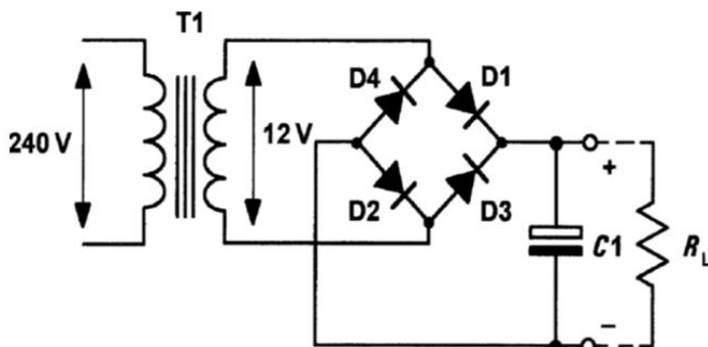
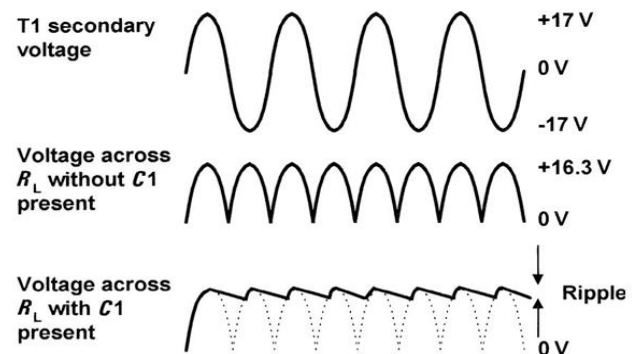

Fig. 1.11: (a) Bridge rectifier with reservoir capacitor



(b) Voltage waveforms

1.1.7 Voltage Regulator

- A voltage regulator provides a constant DC output voltage that is independent of AC line voltage variations, load current and temperature.
- A simple voltage regulator is shown in Fig. 1.12.
- R_S is included to limit the Zener current to a safe value when the load is disconnected.
- When a load (R_L) is connected, Zener current (I_Z) will fall as current is diverted into load resistance.

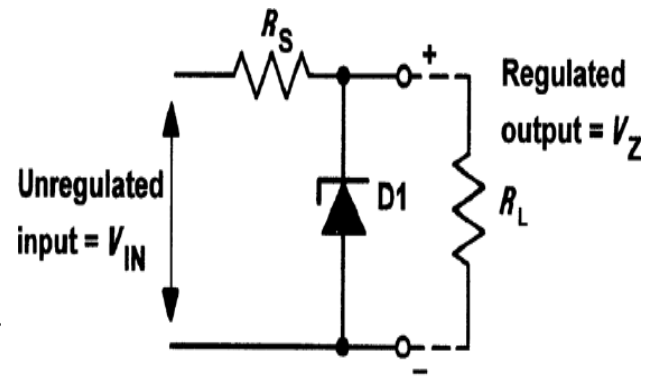

- The output voltage (V_Z) will remain at the Zener voltage until regulation fails at the point at which potential divider formed by R_S & R_L produces a lower output voltage that is less than V_Z .
- The Zener voltage is given by:

$$V_Z = V_{IN} \times \frac{R_L}{R_L + R_S} \quad \text{where } V_{IN} \text{ is the unregulated input voltage.}$$

- Thus the maximum value for R_S can be calculated from:
$$R_S \text{ max.} = R_L \times \left(\frac{V_{IN}}{V_Z} - 1 \right)$$
- The power dissipated in the Zener diode will be given by $P_Z = V_Z \times I_Z$
- Hence the minimum value for R_S can be determined from the off-load condition when:

$$R_S \text{ min.} = \frac{V_{IN} - V_Z}{I_Z} = \frac{V_{IN} - V_Z}{\left(\frac{P_Z \text{ max.}}{V_Z} \right)} = \frac{(V_{IN} - V_Z) \times V_Z}{P_Z \text{ max.}} = \frac{V_{IN} V_Z - V_Z^2}{P_Z \text{ max.}}$$

- The internal resistance appears at the output of the supply and defined as change in output voltage to change in output current

$$R_{out} = \frac{\text{change in output voltage}}{\text{change in output current}} = \frac{\Delta V_{out}}{\Delta I_{out}} \quad \text{where,}$$

ΔV_{OUT} represents a small change in output (load) current and ΔI_{OUT} represents a corresponding small change in output voltage.

- The regulation of a power supply is given by the relationship:

$$\text{Regulation} = \frac{\text{change in output voltage}}{\text{change in line (input) voltage}} \times 100\%$$

- Ideally, the value of regulation should be very small.

Problem 1.3: A 5 V Zener diode has a maximum rated power dissipation of 500 mW. If the diode is to be used in a simple regulator circuit to supply a regulated 5 V to a load having a resistance of 400 ohms, determine a suitable value of series resistor for operation in conjunction with a supply of 9 V.

Solution: The maximum value for the series resistor is:

$$R_S \text{ max.} = R_L \times \left(\frac{V_{IN}}{V_Z} - 1 \right) = 400 \times \left(\frac{9}{5} - 1 \right) = 400 \times (1.8 - 1) = 320 \Omega$$

The minimum value for the series resistor is:

$$R_S \text{ min.} = \frac{V_{IN} V_Z - V_Z^2}{P_Z \text{ max.}} = \frac{(9 \times 5) - 5^2}{0.5} = \frac{45 - 25}{0.5} = 40 \Omega$$

Hence a suitable value for R_S would be 150 ohms (Midway between two extremes).

1.1.8 Voltage Multipliers

- By adding a second diode and capacitor, the output of a simple half-wave rectifier can be increased.
- A voltage doubler using this technique is shown in Fig. 1.13.
- In this arrangement C1 will charge to the positive peak secondary voltage while C2 will charge to the negative peak secondary voltage.
- Since the output is taken from C1 and C2 connected in series the resulting output voltage is twice that produced by one diode alone
- The voltage doubler can be extended to produce higher voltages using the cascade arrangement shown in Fig. 1.14.
- C1 charges to positive peak secondary voltage, while C2 and C3 charges to twice the positive peak secondary voltage.
- The result is that the output voltage is the sum of the voltages across C1 and C3 which is 3 times the voltage that would be produced by a single diode.

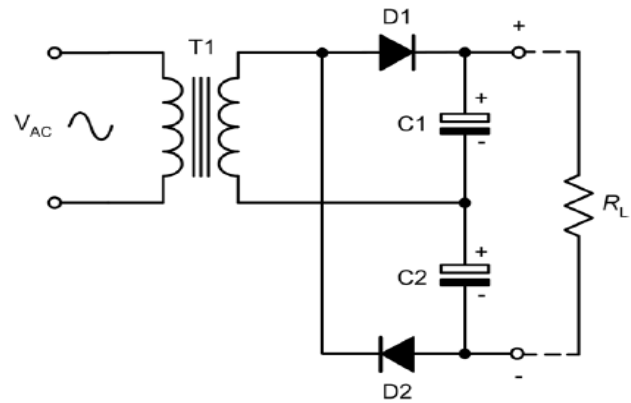

Fig. 1.13: Voltage Doubler

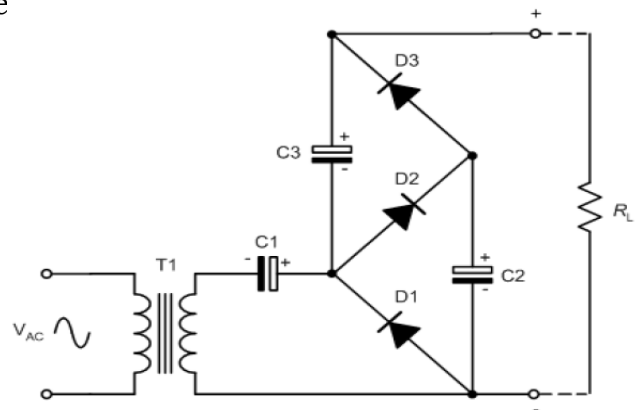

Fig. 1.14: A voltage tripler

1.2 AMPLIFIER

- An amplifier is an electronic device that can increase the power of a signal (a time-varying voltage or current). It is a two port electronic circuit used to increase the amplitude of a signal applied to its input terminals.
- The amount of amplification provided by an amplifier is measured by its gain: the ratio of output voltage, current, or power to input.

1.2.1 Types of Amplifier

AC Amplifier

- Stages are coupled together in such a way that dc levels are isolated and only the ac components of a signal are transferred from stage to stage.

DC Amplifier

- Stages are coupled together in such a way that stages are not isolated to d.c. potentials.
- Both a.c. and d.c. signal components are transferred from stage to stage.

Large Signal Amplifier

- Designed to cater for appreciable voltage and/or current levels (from 1V - 100V or more).

Small signal amplifier

- Designed to cater for low-level signals (normally less than 1 V and often much smaller).
- Specially designed to combat the effects of noise.

Audio frequency amplifier

- Operate in the band of frequencies that is normally associated with audio signals (e.g. 20 Hz to 20 kHz).

Radio Frequency amplifiers

- Operate in the band of frequencies that is normally associated with radio signals (e.g. from 100 kHz to over 1 GHz).

Wideband amplifiers

- Capable of amplifying a very wide range of frequencies, typically from a few tens of hertz to several megahertz.

Low noise amplifiers

- Designed so that they contribute negligible noise to the signal being amplified.
- Designed for use with very small signal levels (usually less than 10 mV or so).

Gain of an amplifier

- Important parameters of amplifier are the amount of amplification or gain that it provides.
- Gain is simply the ratio of output voltage to input voltage, output current to input current, or output power to input power.
- These are called as: Voltage gain (A_v), Current gain (A_i) and Power gain (A_p), given by

$$A_v = \frac{V_{out}}{V_{in}} \quad A_i = \frac{I_{out}}{I_{in}} \quad A_p = \frac{P_{out}}{P_{in}}$$

- Since power is the product of current and voltage ($P = IV$), we can infer that:

$$A_p = \frac{P_{out}}{P_{in}} = \frac{I_{out} \times V_{out}}{I_{in} \times V_{in}} = \frac{I_{out}}{I_{in}} \times \frac{V_{out}}{V_{in}} = A_I \times A_V$$

Problem 1.4: An amplifier produces an output voltage of 2 V for an input of 50 mV. If the input and output currents in this condition are, respectively, 4 mA and 200 mA, determine:
 (a) The voltage gain (b) the current gain (c) the power gain.

Solution: Given: $V_i = 50\text{mV}$, $V_{out} = 2\text{V}$, $I_{in} = 4\text{mA}$, $I_{out} = 200\text{mA}$

(a) The voltage gain is calculated from: $A_V = V_{out} / V_{in} = 2\text{V} / 50\text{mV} = 40$.

(b) The current gain is calculated from: $A_I = I_{out} / I_{in} = 200\text{mA} / 4\text{mA} = 50$

(c) The power gain is calculated from: $A_p = A_V \times A_I = 40 \times 50 = 2000$.

1.2.2 Input and output resistance

- Input resistance is the ratio of input voltage to input current and is expressed in ohms.
- Input of an amplifier is normally purely resistive & measured in mid-band frequency.
- In some cases, the reactance of the input may become appreciable & in such cases we would refer to **input impedance** rather than input resistance.
- Output resistance is the ratio of open-circuit output voltage to short-circuit output current and is measured in ohms.
- If output is not purely resistive, then referred as **output impedance**.
- Fig. 1.15 shows how the input and output resistances are 'seen' looking into the input and output terminals, respectively.

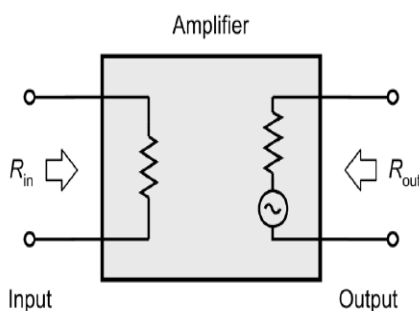

Fig.1.15: Input and output resistances 'seen' looking into the input and output terminals, respectively

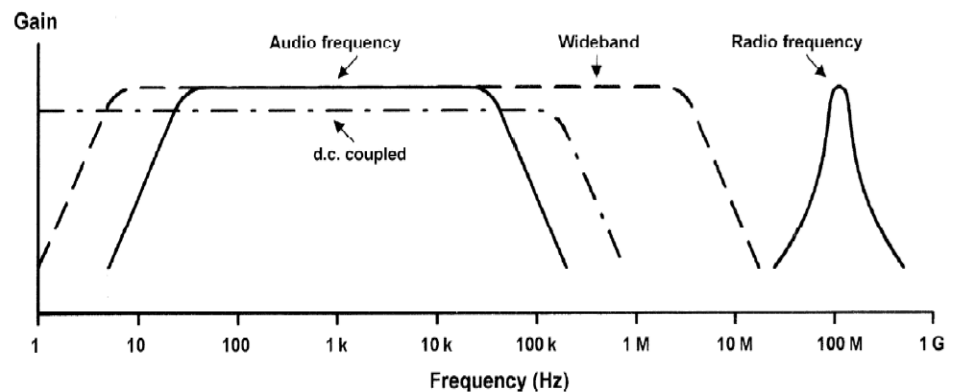

Fig. 1.16: Frequency response and bandwidth (output power plotted against frequency)

1.2.3 Frequency Response

- Frequency response characteristics for various types of amplifier are shown in Fig. 1.16.
- The frequency response of an amplifier is usually specified in terms of the upper and lower cut-off frequencies of the amplifier.
- These frequencies are those at which the output power has dropped to 50% (known as the -3 dB points) or where the voltage gain has dropped to 70.7% of its mid-band value.

1.2.4 Bandwidth

- The bandwidth of an amplifier is usually taken as the difference between the upper and lower cut-off frequencies.
- The bandwidth of an amplifier must be sufficient to accommodate the range of frequencies present within the signals that it is to be presented with.
- Figs 1.17 (a) and (b), shows the bandwidth expressed in terms of either power or voltage.

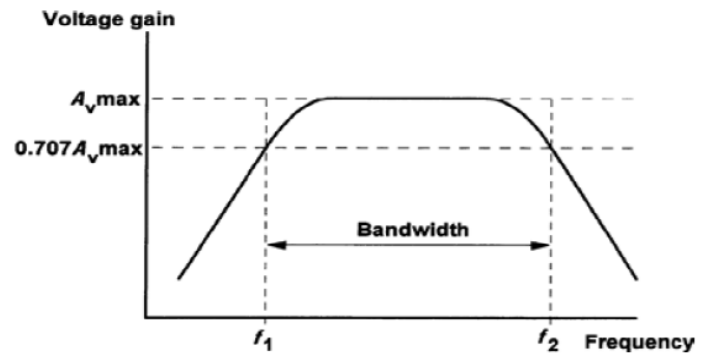
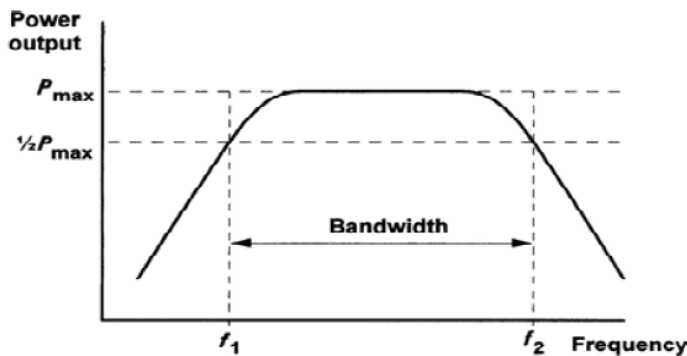

Fig. 1.17: (a) Frequency response and bandwidth (output power plotted against frequency)

(b): Frequency response and bandwidth (output voltage plotted against frequency)

1.2.5 Phase Shift

- It is the phase angle between the input and output signal voltages measured in degrees.
- The measurement is usually carried out in the mid-band.
- Single-stage transistor amplifiers provide phase shifts of either 180° or 360° .

1.2.6 Negative Feedback

- Most of the practical amplifiers use negative feedback to precisely control the gain, reduce distortion and improve bandwidth.
- Gain can be reduced to a manageable value by feeding back a small proportion of the output. The amount of feedback determines the overall (or closed-loop) gain.
- Negative feedback has the effect of reducing the overall gain of the circuit.

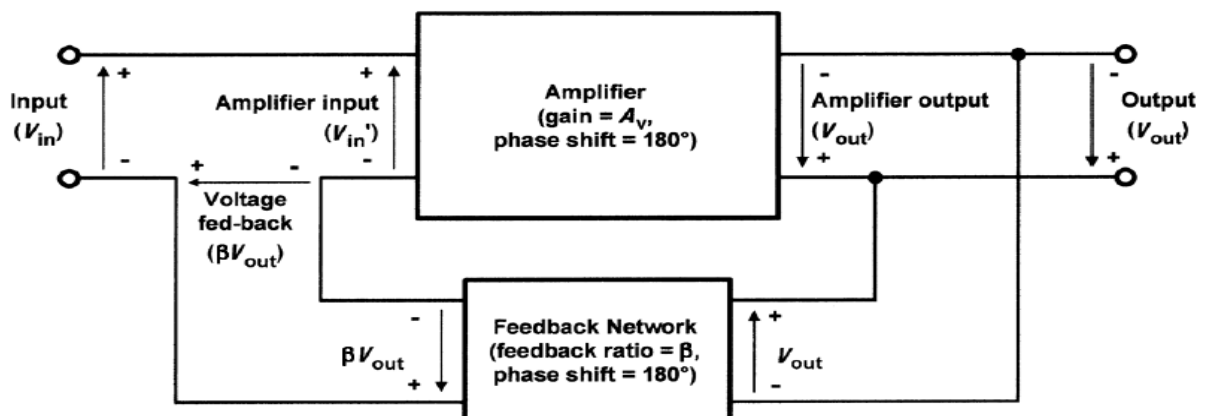

Fig. 1.18: Amplifier with negative feedback applied

- In positive feedback, the output is fed back in such a way as to reinforce the input (rather than to subtract from it).
- Fig. 1.18 shows the block diagram of an amplifier stage with negative feedback applied.
- The proportion of the output voltage fed back to the input is given by β and the overall voltage gain will be given by: Overall Gain $G = V_{out} / V_{in}$
- Applying KVL to the input, $V_{in}' = V_{in} - V_{out} \beta$
- Thus, $V_{in} = V_{in}' + V_{out} \beta$ and $V_{out} = A_v \times V_{in}'$

$$\text{Hence: Overall gain, } G = \frac{A_v \times V_{in}'}{V_{in}' + \beta V_{out}} = \frac{A_v \times V_{in}'}{V_{in}' + \beta (A_v \times V_{in}')} \quad \text{Thus: } G = \frac{A_v}{1 + \beta A_v}$$

- Therefore, the overall gain with negative feedback applied will be less than the gain without feedback.

Problem 1.5: An amplifier with negative feedback applied has an open-loop voltage gain of 50, and one-tenth of its output is fed back to the input (i.e. $\beta = 0.1$).

- Determine the overall voltage gain with negative feedback applied.
- If the amplifier's open-loop voltage gain increases by 20%, determine the percentage increase in overall voltage gain.

Solution: (a) With negative feedback applied the overall voltage gain will be given by:

$$G = \frac{A_v}{1 + \beta A_v} = \frac{50}{1 + (0.1 \times 50)} = \frac{50}{6} = 8.33$$

- The new value of voltage gain will be given by:

$$A_v' = A_v + 0.2 A_v = 50 + 0.2(50) = 60$$

The overall voltage gain with negative feedback will then be:

$$G = \frac{A_v'}{1 + \beta A_v'} = \frac{60}{1 + (0.1 \times 60)} = \frac{60}{7} = 8.57$$

The increase in overall voltage gain, expressed as a percentage, will thus be:

$$\frac{8.57 - 8.33}{8.33} \times 100\% = 2.88\%$$

1.2.7 Multi-stage amplifiers

- In order to provide sufficiently large values of gain, it is frequently necessary to use a number of interconnected stages within an amplifier.
- The overall gain of an amplifier with several stages (i.e. a multi-stage amplifier) is simply the product of the individual voltage gains.
- Hence: $A_v = A_{v1} \times A_{v2} \times A_{v3}$, etc.
- The bandwidth of a multistage amplifier will be less than the bandwidth of each

individual stage. In other words, an increase in gain can only be achieved at the expense of a reduction in bandwidth.

- Signals can be coupled between the individual stages of a multi-stage amplifier using a suitable coupling device.

Types of coupling

- **RC coupling:** In this coupling method, the stages are coupled together using capacitors having a low reactance at the signal frequency and resistors.
- **L-C coupling:** In this method, the stages are coupled together using inductors having a high reactance at the signal frequency. This type of coupling is generally only used in RF and high-frequency amplifiers.
- **Transformer Coupling:** In this method, the transformer is used as coupling device.

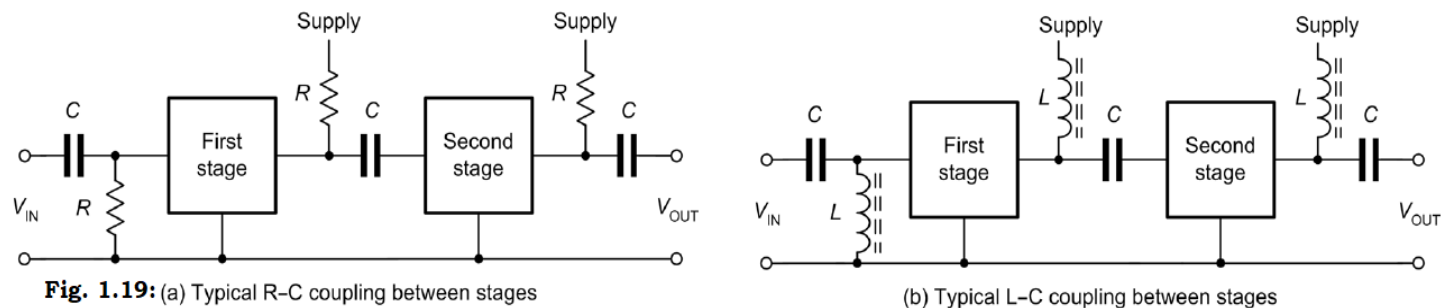
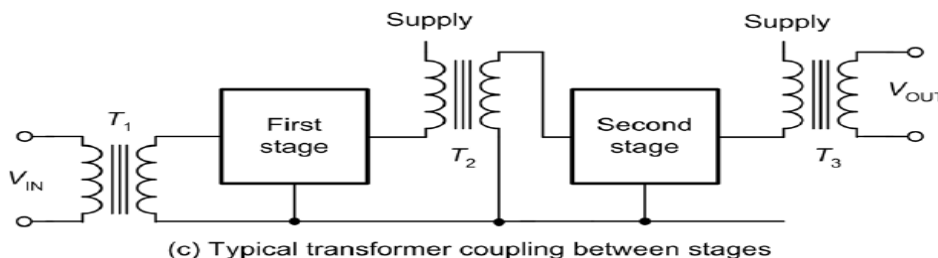

Fig. 1.19: (a) Typical R-C coupling between stages

(b) Typical L-C coupling between stages



(c) Typical transformer coupling between stages

1.3 Operational Amplifiers

- An op-amp is a multi-stage, direct coupled, high gain negative feedback amplifier used to amplify AC and DC input signals.
- Applications of op-amp: Active filters, oscillators, comparators, voltage regulators, instrumentation & control systems, pulse generators, square wave generators etc.
- The symbol for an operational amplifier is shown in Fig. 1.20.
- The '+' sign indicates zero phase shift while the '-' sign indicates 180° phase shift. Since 180° phase shift produces an inverted waveform, the '-' input is often referred to as the **inverting input**.

The '+' input is known as the **non-inverting input**.

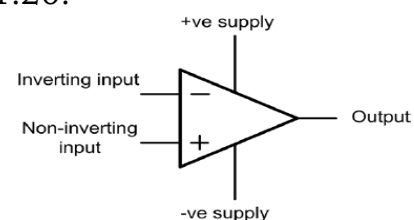

Fig. 1.20: Symbol for an operational amplifier

1.3.1 Operational amplifier parameters

1. Open-loop voltage gain

- Open-loop voltage gain of an operational amplifier is defined as the ratio of output voltage to input voltage measured with no feedback applied.
- It may be thought as the 'internal' voltage gain of the device, given by: $A_{V(OL)} = V_{OUT} / V_{IN}$
- In practice, this value is exceptionally high (typically greater than 100,000).
- The open-loop voltage gain is often expressed in **decibels (dB)** rather than as a ratio:
 $A_{V(OL)} = 20 \log_{10} (V_{OUT} / V_{IN})$
- Most operational amplifiers have open-loop voltage gains of 90 dB or more.

2. Closed-loop voltage gain:

- It is defined as the ratio of output voltage to input voltage measured with a small proportion of the output fed-back to the input (i.e. with feedback applied).
- The effect of providing negative feedback is to reduce the loop voltage gain.
- It is given by: $A_{V(CL)} = V_{OUT} / V_{IN}$
- Value of $A_{V(CL)}$ is very much less than value of $A_{V(OL)}$.

3. Input resistance:

- The input resistance of an operational amplifier is defined as the ratio of input voltage to input current expressed in ohms.
- Ideal value is ∞ and practical value ranges from $2M\Omega$ to $10^{12} \Omega$
- It is given by: $R_{IN} = V_{IN} / I_{IN}$

4. Output resistance

- The output resistance of an operational amplifier is defined as the ratio of open-circuit output voltage to short-circuit output current expressed in ohms.
- Ideal value is 0Ω and practical values range from less than 10Ω to around 100Ω .
- It is given by: $R_{OUT} = V_{OUT(OC)} / I_{OUT(OC)}$

5. Input offset voltage:

- An ideal operational amplifier would provide zero output voltage when 0V difference is applied to its inputs. In practice, due to imperfect internal balance, there may be some small voltage present at the output.
- The voltage that must be applied differentially to the operational amplifier input in order to make the output voltage exactly zero is known as the input offset voltage.
- Input offset voltage may be minimized by applying large amounts of negative feedback.
- Ideal value is 0V and typical values range from 1mV to 15mV.

6. Full-power bandwidth:

- The full-power bandwidth for an operational amplifier is equivalent to the frequency at which the maximum undistorted peak output voltage swing falls to 0.707 of its low-frequency (d.c.) value.
- Typical full-power bandwidths range from 10 kHz to over 1 MHz

7. Slew rate: Slew rate is the rate of change of output voltage with time, when a rectangular step input voltage is applied. It is the rate of change of output voltage with time in response to a perfect step-function input.

Hence: $SR = \Delta V_{OUT} / \Delta t$, where ΔV_{OUT} is the change in output voltage and Δt is the corresponding interval of time.

1.3.2 Operational amplifier characteristics

- Characteristics for an 'ideal' operational amplifier are:
 1. The open-loop voltage gain should be very high (ideally infinite).
 2. The input resistance should be very high (ideally infinite).
 3. The output resistance should be very low (ideally zero).
 4. Full-power bandwidth should be as wide as possible.
 5. Slew rate should be as large as possible.
 6. Input offset should be as small as possible.
- Comparison of amplifier parameters for 'ideal' and 'real' devices is given below:

Parameter	Ideal	Real
Voltage gain	Infinite	100,000
Input resistance	Infinite	100 M Ω
Output resistance	Zero	20 Ω
Bandwidth	Infinite	2 MHz
Slew rate	Infinite	10 V/ μ s
Input offset	Zero	Less than 5 mV

1.3.3 Operational amplifier configurations

1) Inverting operational Amplifier : Input signal V_{IN} is applied to the inverting terminal of the amplifier and output V_{OUT} is inverted version (180° phase shift) of input V_{IN} .

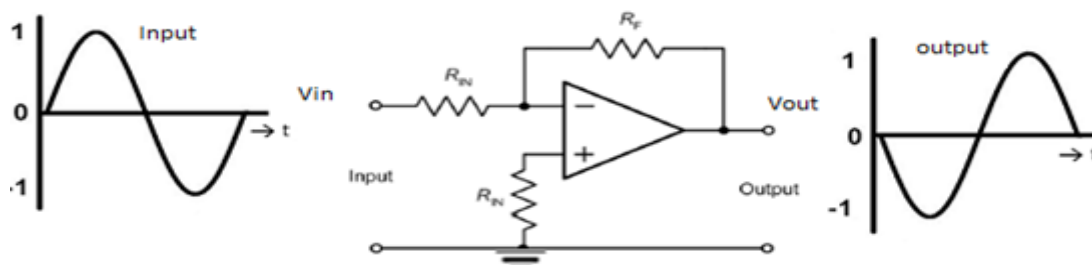

Fig. 1.21: Inverting Amplifier

2) Non-inverting operational Amplifier: Input signal V_{IN} is applied to the non-inverting terminal of the amplifier & output V_{OUT} is non-inverted version (0° phase shift) of input V_{IN} .

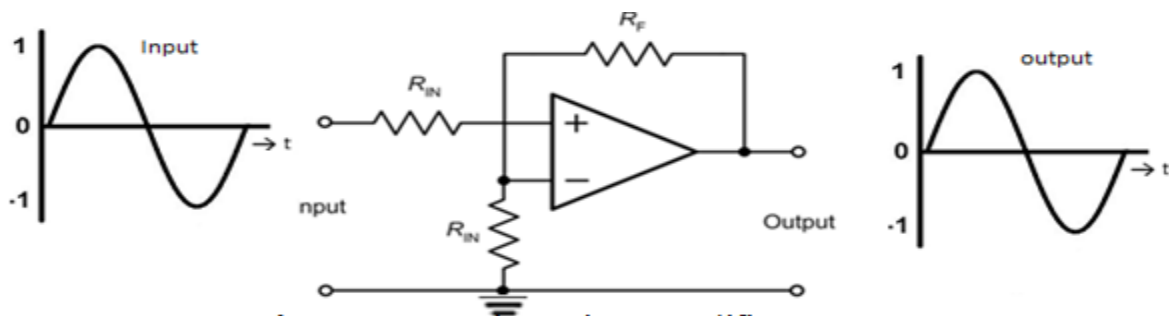

Fig. 1.22: Non inverting Amplifier

3) Differential amplifiers: Differential amplifiers amplify the difference between two input voltage signals of V_1 and V_2 .

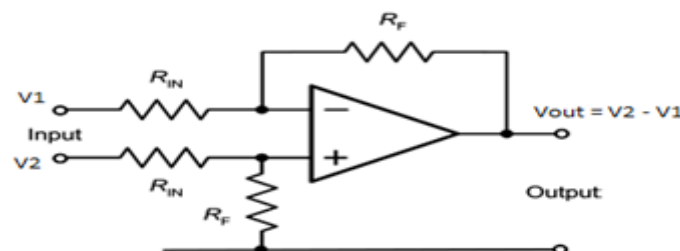

Fig. 1.23: Differential Amplifier

1.3.4 Operational amplifier circuits

1. Voltage followers: Output voltage V_{OUT} follows the input voltage V_{IN} so the circuit is named as op-amp voltage follower. The output is connected directly back to the (-) inverting input so that the feedback is 100% and V_{IN} is exactly equal to V_{OUT} .

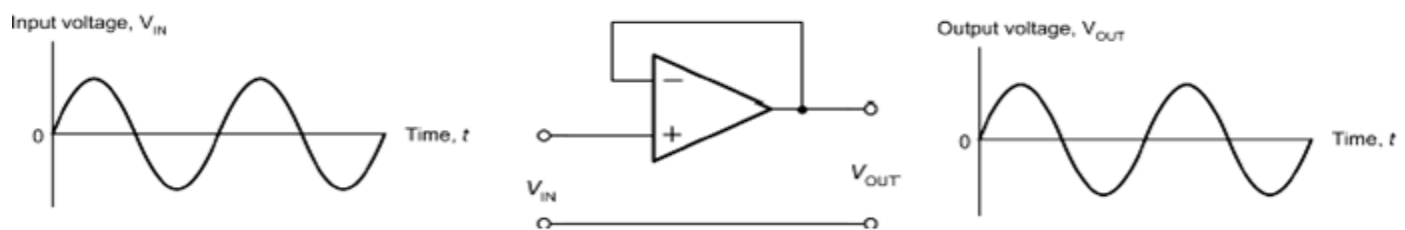

Fig. 1.24: A Voltage Follower

This amplifier has a voltage gain of 1 (i.e. unity), a very high input resistance and a very high output resistance. This stage is often referred to as a buffer and is used for matching a high-impedance circuit to a low-impedance circuit.

2. Differentiator amplifier

Differentiator produces an output voltage V_{OUT} that is proportional to the rate of change of the input voltage V_{IN} . An op-amp differentiator is an inverting amplifier, which uses a capacitor C in series with the input voltage V_{IN} and a feedback resistor R is connected between V_{OUT} and inverting (-) input.

If input is a square wave to a differentiator, output is pulses.

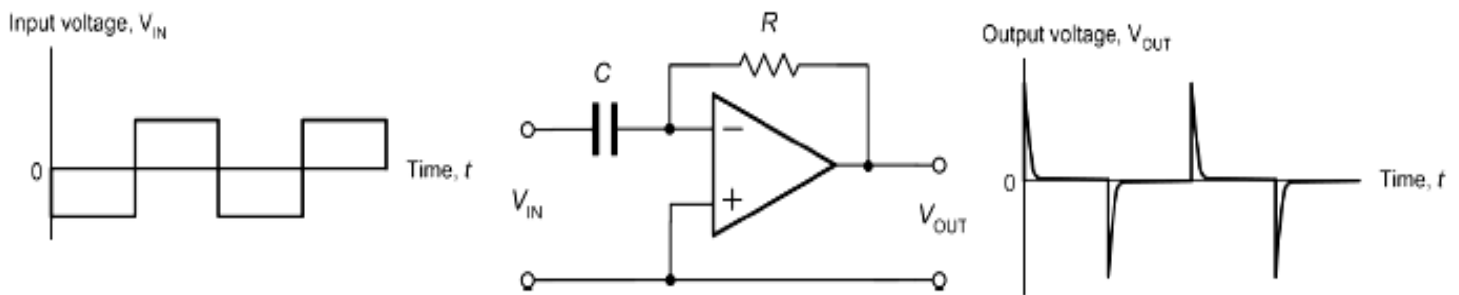

Fig. 1.25: A Differentiator

3. Integrator Amplifier: Integrator produces output voltage V_{OUT} that is proportional to the integral of the input voltage V_{IN} . An op-amp integrator is an inverting amplifier, which uses a resistor R in series with the input voltage V_{IN} and a capacitor C is connected between V_{OUT} and inverting (-) input as feedback.

If input is a square wave, output of an integrator is a triangular (inverted) wave.

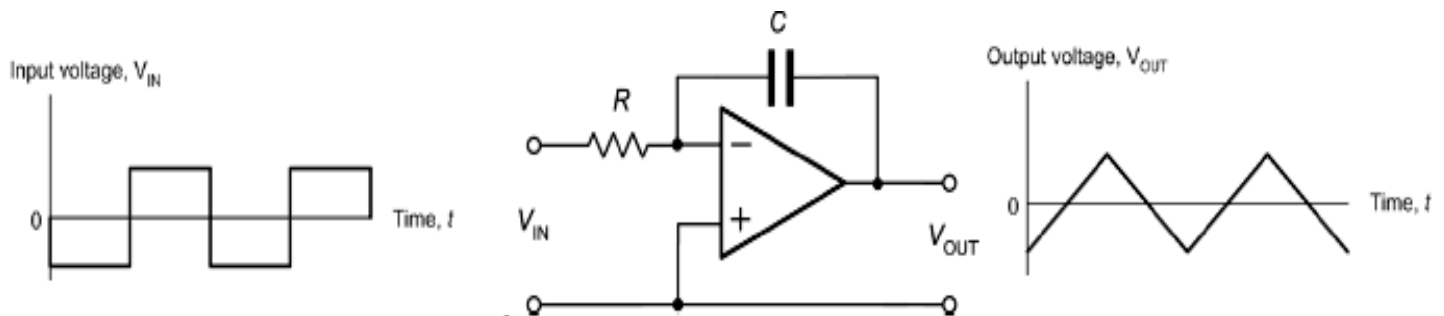

Fig. 1.26: An Integrator

4. Comparator: A comparator using an operational amplifier is shown in Fig. 1.27(a). A voltage comparator compares the magnitudes of two voltage inputs and determines which is the larger of the two. The output voltage produced by the operational amplifier will rise to the maximum possible value whenever the voltage present at the non-inverting input exceeds that present at the inverting input. Conversely, the output voltage produced by the operational amplifier will fall to the minimum possible value whenever the voltage present at the inverting input exceeds that present at the non-inverting input. Typical input and output waveforms for a comparator are shown in Fig. 1.27(b).

5. Summing amplifiers: A summing amplifier using an operational amplifier is shown in Fig. 1.28(a). This circuit produces an output that is the sum of its two input voltages. However, since the operational amplifier is connected in inverting mode, the output voltage is given by: $V_{OUT} = -(V_1 + V_2)$ where V_1 and V_2 are the input voltages.

Typical input and output waveforms for a summing amplifier are shown in Fig. 1.28(b). A typical application is that of 'mixing' two input signals to produce an output voltage that is the sum of the two.

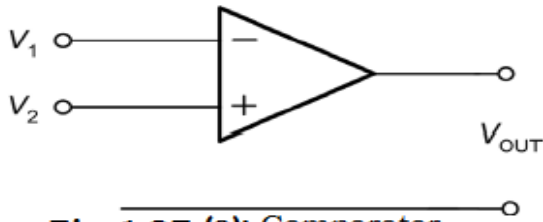

Fig. 1.27 (a): Comparator

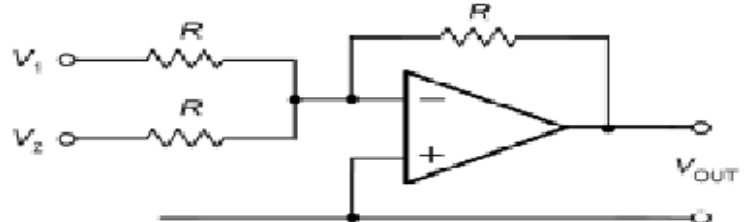

Fig. 1.28 (a): A Summing Amplifier

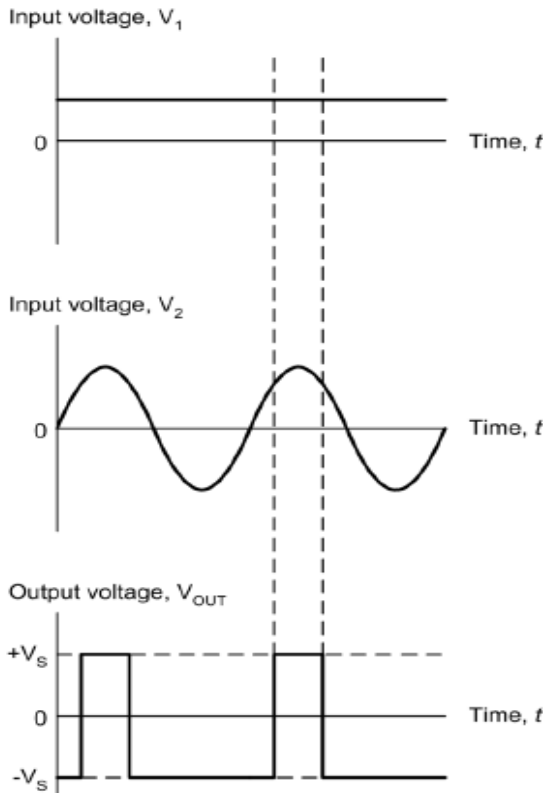

Fig. 1.27 (b) : Typical Input & output waveforms for a comparator

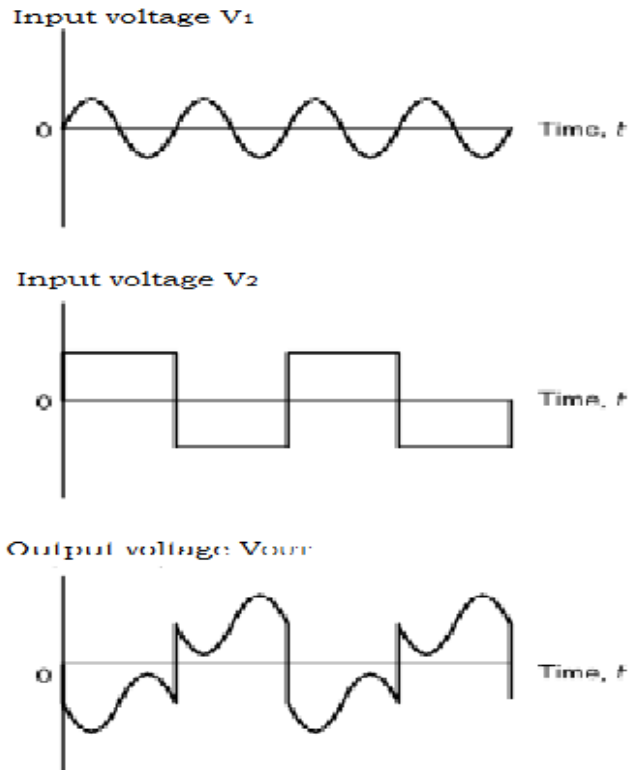

Fig. 1.28 (b): Typical input and Output waveforms

1.4 Oscillators

Negative feedback can be applied to an *amplifier* to form the basis of a stage which has a precisely controlled gain. Similarly, positive feedback can be applied to an *oscillator*, where the output is fed back in such a way as to reinforce the input.

1.4.1 Positive Feedback

Fig. 1.29 shows the block diagram of an amplifier stage with positive feedback applied. The amplifier provides a phase shift of 180° and the feedback network provides a further 180°. Thus the overall phase shift is 0°.

The Overall Gain is given by: $G = V_{out} / V_{in}$

By applying Kirchhoff's Voltage Law, $V_{in}' = V_{in} + V_{out} \beta$

Thus, $V_{in} = V_{in}' - V_{out} \beta$

The internal gain of amplifier is given by: $A_v = V_{out} / V_{in}'$ or $V_{out} = A_v \times V_{in}'$

Hence, Overall gain, $G = \frac{A_v \times V_{in}'}{V_{in}' - \beta V_{out}} = \frac{A_v \times V_{in}'}{V_{in}' - \beta(A_v \times V_{in}')}$ Thus, $G = \frac{A_v}{1 - \beta A_v}$

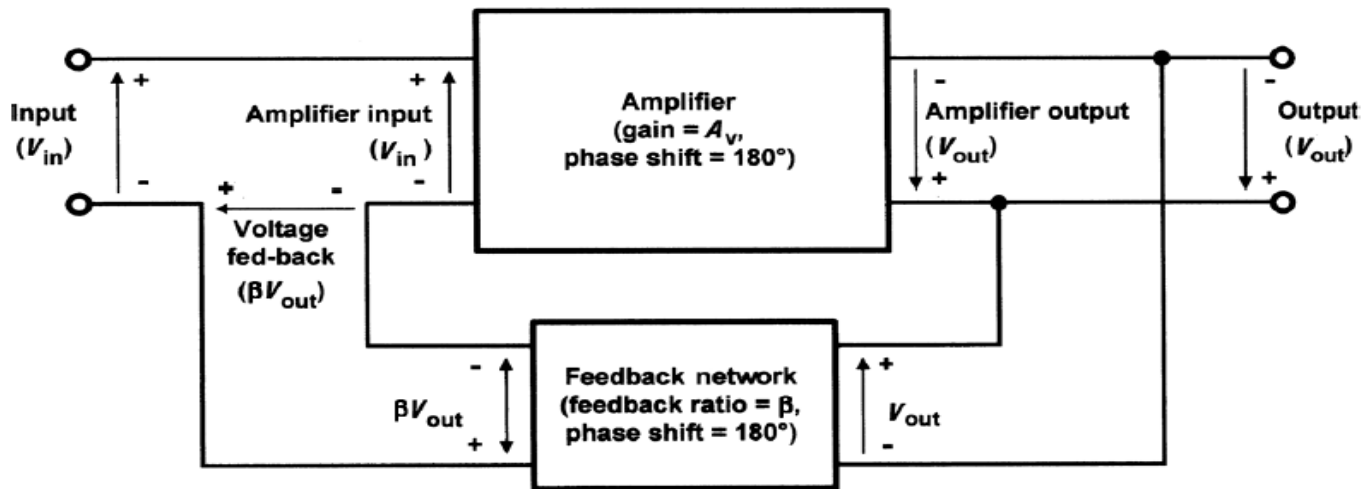

Fig. 1.29: Amplifier with positive feedback applied

1.4.2 Conditions for Oscillations

The conditions for oscillation are:

- The feedback must be positive (i.e. the signal fed back must arrive back in-phase with the signal at the input);
- the overall loop voltage gain must be greater than 1 (i.e. the amplifier's gain must be sufficient to overcome the losses associated with any frequency selective feedback network).

Hence, to create an *oscillator* we simply need an *amplifier* with sufficient gain to overcome the losses of the network that provide positive feedback.

1.4.3 Ladder network oscillator

A number of circuits can be used to provide 180° phase shift, one of the simplest being a three stage C-R ladder network.

A simple phase-shift oscillator based on a three stage C-R ladder network is shown in Fig. 1.30. TR1 operates as a conventional common-emitter amplifier stage with R1 and R2 providing base bias potential and R3 and C1 providing emitter stabilization. The total phase shift provided by the C-R ladder network is 180° at the frequency of oscillation. The transistor provides the other 180° phase shift in order to realize an overall phase shift of 360° or 0° .

The frequency of oscillation of this circuit shown is given by: $f = 1 / (2\pi RC\sqrt{6})$

For oscillations to occur, $|\beta| > 1/29$

That means, the loss associated with the ladder network is 29, thus the amplifier must provide a gain of at least 29 in order for the circuit to oscillate.

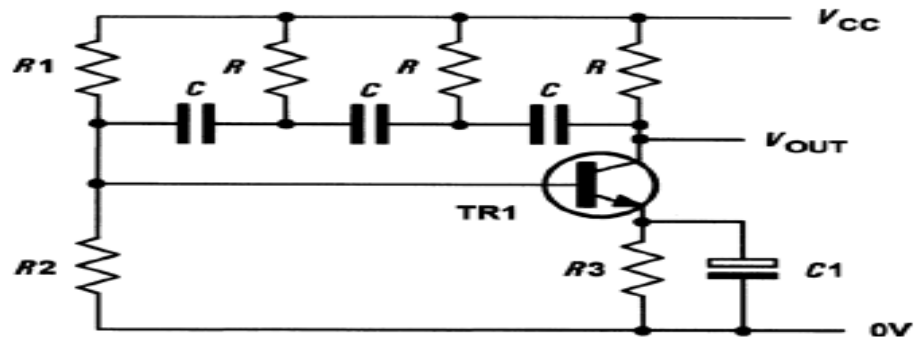

Fig. 1.30: Sine wave oscillator based on a three-stage C-R ladder network

1.4.4 Wien bridge oscillator

An alternative approach to providing the phase shift required is the use of a Wien bridge network (Fig. 9.3). Like the C-R ladder, this network provides a phase shift which varies with frequency. The input signal is applied to A and B while the output is taken from C and D. At one particular frequency, the phase shift produced by the network will be exactly zero (i.e. the input and output signals will be in-phase). If we connect the network to an amplifier producing 0° phase shift which has sufficient gain to overcome the losses of the Wien bridge, oscillation will result. The minimum amplifier gain required to sustain oscillation is given by: $A_v = 1 + \frac{C_1}{C_2} + \frac{R_2}{R_1}$. In most cases, $C_1 = C_2$ and $R_1 = R_2$, hence the minimum amplifier gain will be 3. Particular frequency at which the values of the resistance and the capacitive reactance will become equal, produces maximum output voltage is

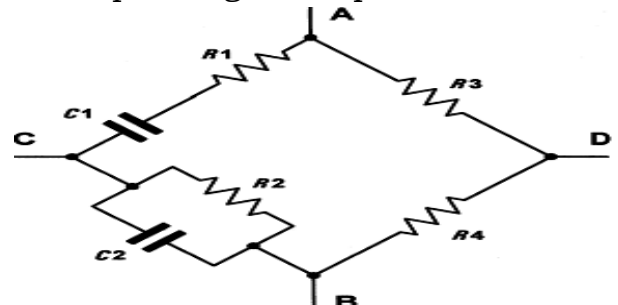

Fig. 1.31: Wein Bridge Network

$$\text{Frequency of oscillations is } f_o = \frac{1}{2\pi\sqrt{R_1 R_2 C_1 C_2}} = \frac{1}{2\pi\sqrt{RC}}; \text{ if } R_1 = R_2 = R \text{ and } C_1 = C_2 = C$$

1.4.5 Multivibrators

Multivibrators are a family of oscillator circuits that produce output waveforms consisting of one or more rectangular pulses. Multivibrators use regenerative (i.e. positive) feedback.

The principal types of multivibrator are:

- Astable multivibrators that provide a continuous train of pulses (also referred to as free-running multivibrators);
- Monostable multivibrators that produce a single output pulse (they have one stable state and are thus sometimes also referred to as 'one-shot');
- Bistable multivibrators that have two stable states and require a trigger pulse or control signal to change from one state to another.

1.4.6 Single-stage astable oscillator

A simple form of astable oscillator that produces a square wave output built using just one operational amplifier, as shown in Fig. 1.31. The circuit employs positive feedback with the output fed back to the non-inverting input via the potential divider formed by R_1 and R_2 .

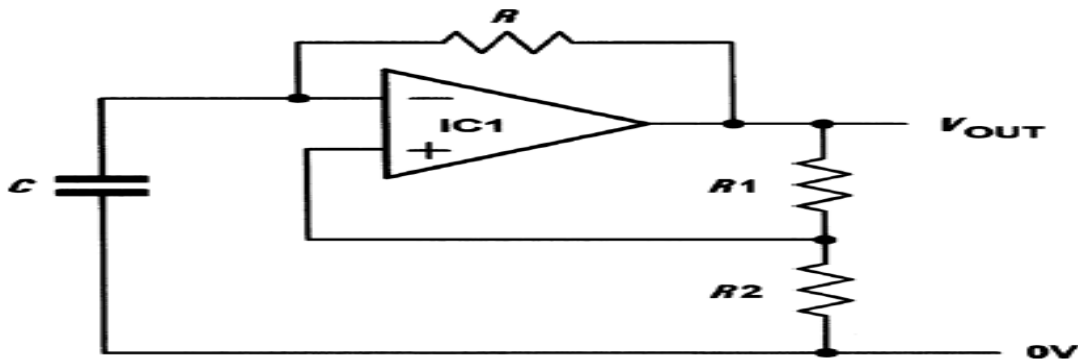

Fig. 1.31: Single-stage astable oscillator using an operational amplifier

When power is turned ON, output V_O normally swings either to $+V_{CC}$ or to $-V_{CC}$.

Assume: i) C is initially uncharged ii) $V_O = +V_{CC}$

The upper threshold voltage (the maximum +ve value at the inverting input) will be given by:

$$V_{UT} = V_{CC} \times \left(\frac{R_2}{R_1 + R_2} \right)$$

The lower threshold voltage (the maximum -ve value at the inverting input) will be given by:

$$V_{LT} = -V_{CC} \times \left(\frac{R_2}{R_1 + R_2} \right)$$

Capacitor C charges through R and the voltage V_C rise exponentially. As voltage across the capacitor is just greater than V_{UT} , the output voltage will rapidly fall to $-V_{CC}$.

Capacitor C will then start to discharge through R and the voltage V_C , fall exponentially. As voltage across the capacitor is slightly lesser than V_{LT} , the output voltage will rise rapidly to $+V_{CC}$. This cycle will continue indefinitely.

1.4.7 Crystal Controlled Oscillator

To obtain a very high level of oscillator stability a *Quartz Crystal* is generally used as the frequency determining device to produce high frequency stability in oscillators. Such oscillators are called as crystal oscillators.

The quartz crystal vibrates whenever a potential difference is applied across its faces. This phenomenon is known as the *piezoelectric effect*. The frequency of oscillation is determined by the crystal's 'cut' and physical size.

Crystals can be manufactured for operation in **fundamental mode** over a frequency range extending from 100 kHz to around 20MHz.